

# FT2 Hall Effect Detection

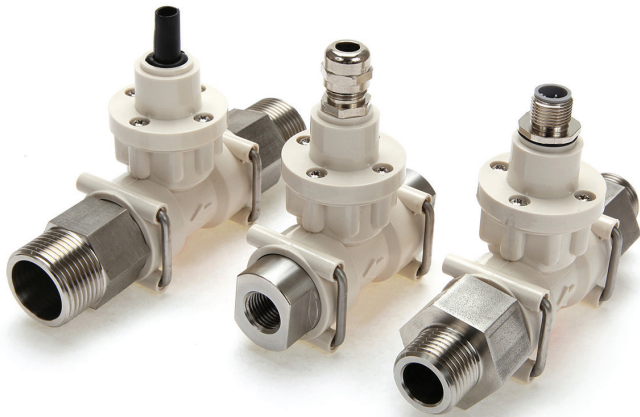

This multi-range radial flow turbine meter uses a low inertia turbine supported on robust sapphire bearings in a chemically resistant housing. Nine flow ranges (0.05 to 160 L/min), a choice of 'plug in' fittings and individual traceable calibration, make this meter one of the most flexible available.

It uses Hall effect sensing so that opaque liquids may still be metered. For OEM applications the fittings can be tailored to suit the installation and speed production. Custom leads or connectors are also available for quantity orders.



### IDEAL FOR

- Opaque liquids
- Laboratory tests
- Cooling equipment
- Semiconductor plant
- Water treatment
- Low viscosity fluids



### FEATURES

- Economical
- PPS body
- Accuracy 1-2% FSD
- Sapphire bearings
- Hall effect sensing
- 9 flow ranges
- Pulse output
- 15 bar pressure rating
- IP65 protection
- Viton™ seal as standard
- Choice of fittings
- 0.1% Repeatability
- 5 to 24 Vdc
- -15°C Min to 125°C

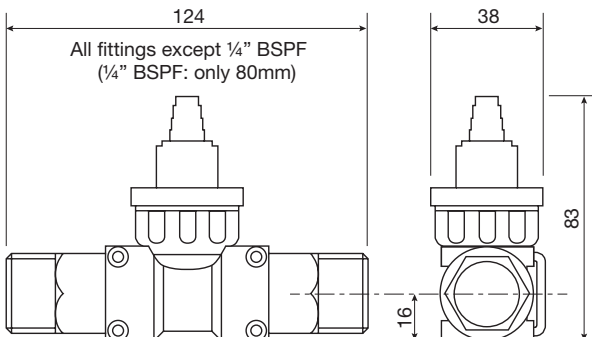

Fitting	Weight in kg			
	PVC	PVDF	Brass	316 St St
8mm hose	0.082			
13mm hose	0.156			
1/4" BSP female			0.195	0.187
1/2" BSP male		0.124	0.279	0.319
3/4" BSP male	0.107	0.108	0.344	0.250
1" BSP male	0.120	0.124	0.377	0.404

**JLC INTERNATIONAL, INC**  
958 Town Center, New Britain, PA 18901

Tel: [\(800\)599-4732](tel:(800)599-4732), [\(215\)340-2650](tel:(215)340-2650)  
Web: [www.jlcinternational.com](http://www.jlcinternational.com)  
Email: [jlcusa@jlcinternational.com](mailto:jlcusa@jlcinternational.com)

## Ordering Codes

### Detector Type

22 = Hall effect

### Electrical Connections

0 = Rubber grommet

P = 4 pin socket

N = IP67 gland

### Model

004

016

045

065

010

030

060

100

160

### Seal Material

V = Viton™

N = Nitrile

E = EPDM

K = Kalrez®

### Process Fitting Size / Type

25 = 1/4" BSP

50 = 1/2" BSP

75 = 3/4" BSP

10 = 1" BSP

8H = 8mm hose

0H = 13mm hose

### Process Fitting Material

B = Brass

S = 316 St St

C = PVC (60°C max)

P = PVDF

### Special Code

S = OEM customer

e.g. **220-100-V-10-B** is a flowmeter with a flow range of 6.0 to 100 L/min, Viton™ seal and 1" BSP brass fittings with a standard 6 point traceable water calibration.

The combination of materials and technology ensures a long life product with reliable operation throughout. Because the flowmeter is so versatile with respect to flow range and fittings every combination of range and fitting is not available. The chart below shows the maximum standard flow rate/fitting we would recommend to attain our performance figures. Alternatives are possible but there would be degradation in the meters performance.



## TECHNICAL SPECIFICATIONS

Model	Flow range L/Min	Linearity % FSD	Typical Freq. Hz.	Approx. 'K' Factor
004	0.05 - 0.5	2.0	133	16000
016	0.12 - 1.6	1.5	207	7700
045	0.13 - 4.5	1.5	318	4250
065	0.25 - 6.5	1.0	260	2400
010	0.60 - 10	1.0	218	1250
030	2.50 - 30	1.5	275	550
060	5.00 - 60	1.5	275	275
100	6.00 - 100	2.0	275	165
160	10.0 - 160	1.5	320	120

Fitting	Recommended Max Flow L/Min	PVC	PVDF	Brass	316 St St
8mm hose	4.5	*			
13mm hose	10	*			
1/4" BSP female	4.5			*	*
1/2" BSP male	30		*	*	*
3/4" BSP male	100	*	*	*	*
1" BSP male	160	*	*	*	*

## Standard Materials of Construction

Body and cap	- PPS
'O' Ring seal	- Viton™
Bearings	- Sapphire
End fittings	- PVDF, PVC, St St or Brass
Magnet	- Ceramic

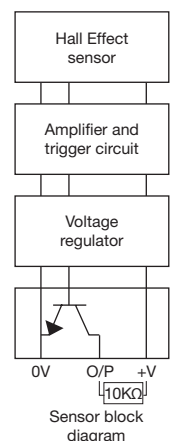

JLC INTERNATIONAL, INC

958 Town Center, New Britain, PA 18901

Tel: (800)-599-4732, (215)-340-2650

Web: [www.jlcinternational.com](http://www.jlcinternational.com)

Email: [jlcusa@jlcinternational.com](mailto:jlcusa@jlcinternational.com)