



—
your partner
in sensor
technology.

+ User Manual Sigma 05

Modular Sensor Platform



Content

1	General Information	3
1.1	Explanation of Warning Notices and Symbols	3
1.2	Safety Instructions	4
1.2.1	General Safety Instructions	4
1.2.2	Intended Use	4
1.2.3	Mounting, Start-up and Operation	5
1.3	Environmental Aspects	5
1.4	ESD Protection	5
2	Scope of Supply	6
3	Product Description	6
3.1	General	6
3.2	Dimensions	6
3.3	Device Mounting	6
3.4	Electrical Connection	7
3.5	Sensing Probes	8
3.5.1	Sigma Plug-and-Play	8
3.5.2	Sigma Compatible E+E Probes and Sensors	8
3.6	Probe Interface: RS485 with Modbus RTU Protocol	9
3.7	Electronics Board	9
3.8	LED Array Indication	10
3.9	Display Functionality	10
3.9.1	Power Up, Scan	10
3.9.2	Normal Operation	11
3.9.3	Configuration	11
4	Plug-and-Play Operation / Setup	12
4.1	General	12
5	Manual Operation / Setup	15
6	Maintenance and Service	16
6.1	Display Change and Retrofitting	16
6.2	Firmware Update	16
6.3	Reference Probe	16
6.4	Repairs	16
6.5	Error Indication on the Analogue Output (NAMUR)	16
6.6	Spare Parts	17
7	Accessories	17
8	Technical Data	18
9	Conformity	19
9.1	Declarations of Conformity	19
9.2	FCC Part 15 Compliance Statement	19
9.3	ICES-003 Compliance Statement	19
9.4	DNV Type Approval	19

1 General Information

This user manual serves for ensuring proper handling and optimal functioning of the device. The user manual shall be read before commissioning the equipment and it shall be provided to all staff involved in transport, installation, operation, maintenance and repair. E+E Elektronik Ges.m.b.H. does not accept warranty and liability claims neither upon this publication nor in case of improper treatment of the described products.

All information, technical data and diagrams included in this document are based on the information available at the time of writing. It may contain technical inaccuracies and typographical errors. The contents will be revised on a regular basis and changes will be implemented in subsequent versions. The described product(s) and the contents of this document may be changed or improved at any time without prior notice.

All rights reserved by E+E Elektronik Ges.m.b.H. No part of this document may be reproduced, published or publicly displayed in any form or by any means, nor may its contents be modified, translated, adapted, sold or disclosed to a third party without prior written permission of E+E Elektronik Ges.m.b.H.

PLEASE NOTE

Find this document and further product information on our website at www.epluse.com/sigma05.

1.1 Explanation of Warning Notices and Symbols

Safety precautions

Precautionary statements warn of hazards in handling the device and provide information on their prevention. The safety instruction labeling is classified by hazard severity and is divided into the following groups:

DANGER

Danger indicates hazards for persons. If the safety instruction marked in this way is not followed, the hazard will very likely result in severe injury or death.

WARNING

Warning indicates hazards for persons. If the safety instruction marked in this way is not followed, there is a risk of injury or death.

CAUTION

Caution indicates hazards for persons. If the safety instruction marked in this way is not followed, minor or moderate injuries may occur.

NOTICE

Notice signals danger to objects or data. If the notice is not observed, damage to property or data may occur.

Informational notes

Informational notes provide important information which stands out due to its relevance.

INFO

The information symbol indicates tips on handling the device or provides additional information on it. The information is useful for reaching optimal performance of the device.

The title field can deviate from "INFO" depending on the context. For instance, it may also read "PLEASE NOTE".

1.2 Safety Instructions

1.2.1 General Safety Instructions

NOTICE

Improper handling of the device may result in its damage.

- The Sigma 05 enclosure, the sensing prods connected shall not be exposed to unnecessary mechanical stress.
- Do not apply the supply voltage to the RS485 data lines.
- The Sigma 05 electronics is sensitive to electrostatic discharge (ESD), appropriate protective measures shall be taken when touching it.
- Use the Sigma 05 only as intended and observe all technical specifications.

1.2.2 Intended Use

The Sigma 05 is a sensor hub for up to 3 E+E probes. Depending on the probes, Sigma 05 can be employed in most various industries and applications. The sensing probes can be connected directly to the host device or via M12 cables. Refer to chapter 3.5 Sensing Probes for details on the “Sigma plug-and-play” and the “Sigma compatible” probes.

The use of the Sigma 05 in any other way than described in this manual bears a safety risk for people and the entire measurement installation and is therefore not allowed.

The manufacturer cannot be held responsible for damages as a result of incorrect handling, installation, and maintenance of the device.

In order to avoid damage to the device or health hazards, the device may not be manipulated with tools other than specifically described in this manual.

The Sigma 05 may only be utilized in accordance with the stipulations of the present user manual and the specification in chapter 8 Technical Data. Otherwise, measurement inaccuracy might occur and failures cannot be ruled out.

WARNING

Non-compliance with the product documentation may cause safety risks for people and the entire measurement installation.

The manufacturer cannot be held responsible for damages as a result of incorrect handling, installation and maintenance of the device.

- Do not use the Sigma 05 in explosive atmosphere or for measurement in aggressive gases.
- This device is not appropriate for safety, emergency stop or other critical applications where device malfunction or failure could cause injury to human beings.
- Handle the sensing probes employed with Sigma 05 according to their respective user manuals.
- The device may not be manipulated with tools other than specifically described in this manual.

NOTICE

Failing to follow the instructions in this user manual may lead to measurement inaccuracy and device failures.

- The Sigma 05 may only be operated under the conditions described in this user manual and within the specification included in chapter 8 Technical Data.
- Unauthorized product modification leads to loss of all warranty claims. Modification may be accomplished only with an explicit permission of E+E Elektronik Ges.m.b.H.!

1.2.3 Mounting, Start-up and Operation

The Sigma 05 Modular Sensor Platform has been produced under state of the art manufacturing conditions, has been thoroughly tested and has left the factory after fulfilling all safety criteria. The manufacturer has taken all precautions to ensure safe operation of the device. The user must ensure that the device is set up and installed in a manner that does not have a negative effect on its safe use. The user is responsible for observing all applicable safety guidelines, local and international, with respect to safe installation and operation of the device. This user manual contains information and warnings that must be observed by the user in order to ensure safe operation.

PLEASE NOTE

The manufacturer or his authorized agent can only be held liable in case of willful or gross negligence. In any case, the scope of liability is limited to the corresponding amount of the order issued to the manufacturer. The manufacturer assumes no liability for damages incurred due to failure to comply with the applicable regulations, operating instructions or the specified operating conditions. Consequential damage is excluded from liability.

WARNING

Non-compliance with the product documentation may cause accidents, personal injury or property damage.

- Mounting, installation, commissioning, start-up, operation and maintenance of the device may be performed by qualified staff only. Such staff must be authorized by the operator of the facility to carry out the mentioned activities.
- The qualified staff must have read and understood this user manual and must follow the instructions contained within. The manufacturer accepts no responsibility for non-compliance with instructions, recommendations and warnings.
- All process and electrical connections shall be thoroughly checked by authorized staff before putting the device into operation.
- Do not install or start-up a device supposed to be faulty. Make sure that such devices are not used accidentally by marking them clearly as faulty.
- A faulty device shall be removed from the process. If the fault cannot be fixed, the device shall be removed from the process.
- Service operations other than described in this user manual may only be performed by the manufacturer.

1.3 Environmental Aspects

PLEASE NOTE

Products from E+E Elektronik Ges.m.b.H. are developed and manufactured in compliance with relevant environmental protection requirements. Please observe local regulations for the disposal of the device.



For disposal, the individual components of the device must be separated according to local recycling regulations. The electronics shall be disposed of correctly as electronics waste.

1.4 ESD Protection



The sensing elements and the electronics board are ESD (electrostatic discharge) sensitive components of the device and must be handled as such. Failure to do so may damage the device by electrostatic discharge when touching exposed sensitive components.

2 Scope of Supply

- The Sigma 05 Modular Sensor Platform according to the ordering guide.
- Quick Guide
- Mounting material
- Test report according to DIN EN 10204-2.2

3 Product Description

3.1 General

The Sigma 05 is a host device acting as a hub for intelligent E+E sensors with RS485 interface and Modbus RTU protocol. It accommodates up to 3 probes and features 2 analogue outputs as well as an optional display for max. 3 measurands. The probes are pluggable and can be easily interchanged.

In its factory setting, the Sigma 05 automatically detects and recognises Sigma plug-and-play probes and performs an autonomous, rule based hub setup. Refer to chapter 4 Plug-and-Play Operation / Setup for details.

For a setup deviating from default, the Sigma 05 can be configured manually by means of the free PCS10 Product Configuration Software. Refer to chapter 5 Manual Operation / Setup for details.

The optional display features backlight and shows up to 3 measurands including the symbol of the physical quantity and the measurement unit. The font size automatically adapts to the number of lines. See chapter 3.9.2 for details. The display can be retrofitted to Sigma 05 devices that were originally ordered without a display. Please refer to chapter 6.6 Spare Parts.

3.2 Dimensions

Values in mm (inch)

Polycarbonate or die-cast aluminium enclosure

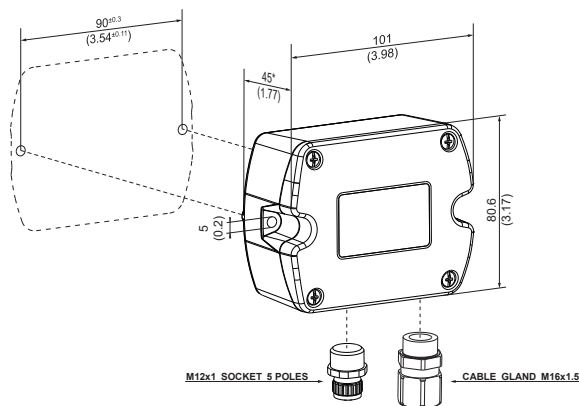

*The polycarbonate enclosure without display: 46 mm (1.81").

3.3 Device Mounting

The Sigma 05 shall be mounted onto a wall or other vertical surface, with the connectors pointing downwards.

Probes may be connected directly to the Sigma 05 or remotely via unshielded connection cables with max. 10 m (32.8 ft) length (available as accessories, see the Sigma 05 datasheet).

NOTICE

For long-term reliability, it is of utmost importance to employ quality extension cables with tightly cast M12 connectors.

3.4 Electrical Connection

⚠ WARNING

Incorrect installation, wiring or power supply may cause overheating and therefore personal injuries or damage to property.

For correct cabling of the device, always observe the presented wiring diagram for the product version used.

The manufacturer cannot be held responsible for personal injuries or damage to property as a result of incorrect handling, installation, wiring, power supply and maintenance of the device.

The Sigma 05 features spring clamp terminals for connecting the power supply and the analogue outputs. The cables are fed into the enclosure through the M16x1.5 cable gland.

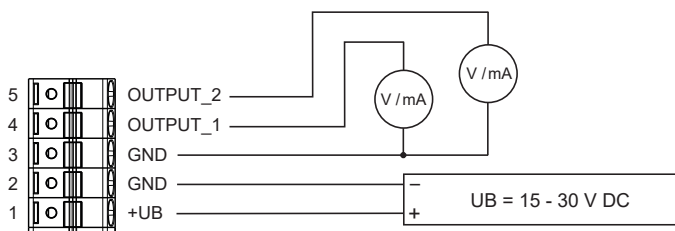
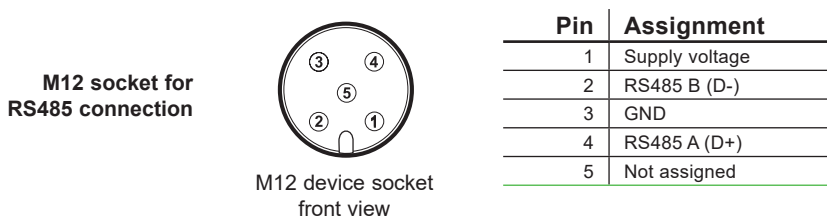

Fig. 1 Voltage supply and outputs



Tab. 1 Sigma 05 pin assignment of the sensing probe connector (RS485 / Modbus RTU protocol)

i PLEASE NOTE

The supply voltage applied to the probes connected to the RS485 interface is always equal to the supply voltage applied to Sigma 05.

NOTICE

Power off Sigma 05 before connecting or disconnecting sensing probes. Failing to do so may cause damages to Sigma 05 and to the probes.

- Choose the Sigma 05 supply voltage (in the range 15 - 30 V DC) to match the probe supply requirements.
- For minimizing the self-heating and its effect onto the measurement accuracy of the RH and / or T probes, use lower supply voltage, e.g. 15 V DC. The self heating affects mostly the RH and / or T probes with metal enclosures and it is negligible for probes with pastic enclosure. Refer to the datasheet of the respective probe.

For Sigma 05 to fulfill IP65 / NEMA 4(X) protection rating, the cable gland for inserting the cable for supply and outputs must be tightly closed. Furthermore, the front cover of Sigma 05 must be properly closed.

i PLEASE NOTE

Some E+E probes with both, analogue output and digital interface, feature a configuration pin (pin no. 5) to enable a configuration via the digital interface. Since the Sigma 05 makes use of the probes' digital interface per default, this pin is not connected.

i PLEASE NOTE



The aluminium enclosure must always be earthed for DNV EMC.

3.5 Sensing Probes

3.5.1 Sigma Plug-and-Play



“Sigma Plug-and-Play” means that Sigma 05 automatically detects the connected E+E Modbus probes at startup and performs a rule-based setup. Depending on the connected probes, a predefined set of up to 5 measurands is assigned to the analogue outputs and to the display, refer to chapter 4 Plug-and-Play Operation / Setup.

E+E Sigma Plug-and-Play Probe	Modbus address
EE072	234
EE074	233
EE671	238
EE680	68
EE872	237
HTP501  1)	69
MOP301  1)	70
HA010406	232

1) DNV approved probe variants and DNV approved Sigma 05 variants form a DNV conform sensor setup with or without display

Tab. 2 Sigma 05 plug-and-play probes and their Modbus address

INFORMATION

Sigma 05, HTP501 and MOP301 are available with DNV approval which form a DNV conform sensor setup with or without display

INFORMATION

Please note that Sigma 05 with display option is available with polycarbonate enclosure only.

3.5.2 Sigma Compatible E+E Probes and Sensors

The “Sigma compatible” E+E probes and sensors fulfill following criteria:

RS485 Serial communication	Selectable values (via EE-PCS)
Baud rate	9 600, 19 200, 38 400, 57 600, 76 800, 115 200
Data bits	8
Parity	None, odd, even
Stop bits	1, 2
Modbus RTU protocol	
Modbus address	1...247
Function Code	03, 04
Data format	According to standard IEEE754, floating point 32 bit, big-endian, word swapped.

Tab. 3 Digital interface options for “Sigma compatible” E+E probes

For operation with Sigma 05 sensor hub the “Sigma compatible” probes require manual setup (see chapter 5 Manual Operation / Setup) and possibly connection adapters.

PLEASE NOTE

All E+E probes and sensors with RS485 interface and Modbus RTU protocol are “Sigma compatible”.

The rest of this manual deals with Sigma plug-and-play probes, unless otherwise specified.

3.6 Probe Interface: RS485 with Modbus RTU Protocol

	Factory settings	Selectable values (via EE-PCS)
Baud rate	9600	9 600, 19 200, 38 400, 57 600, 76 800, 115 200
Data bits	8	8
Parity	Even	None, odd, even
Stop bits	1	1, 2
Modbus address	-	Sigma 05 is Modbus master and does not have an address

Tab. 4 Interface default settings

The recommended settings for multiple devices in a Modbus RTU network are 9 600, 8, even, 1. The Sigma 05 represents 1 unit load in an RS485 network.

RS485 communication settings can be changed with PCS10 Product Configuration Software.

3.7 Electronics Board

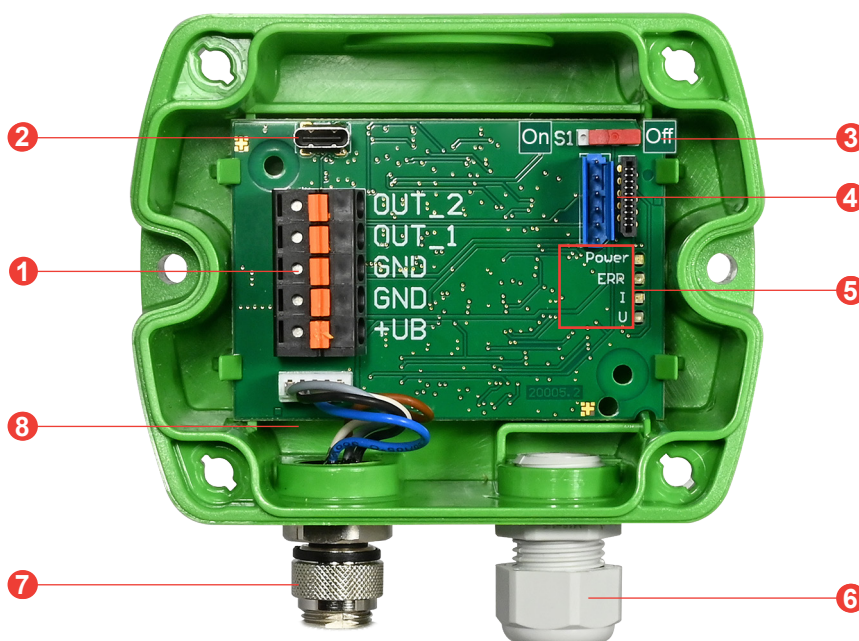



Fig. 2 Sigma 05 electronics board

No.	Function
1	Spring clamp terminals for power supply and analogue outputs
2	USB-C configuration interface
3	Slide switch for the 120 Ω RS485 network termination resistor
4	FFC cable socket for the display
5	LED array  <ul style="list-style-type: none"> Green: Power Red: Error Orange: Current outputs Blue: Voltage outputs <p>The function of each LED is outlined at chapter 3.8 LED Array Indication.</p>
6	M16 cable gland
7	M12 socket: RS485 interface and power supply for the probes
8	Data and power lines towards the probe(s)

Tab. 5 Accessible board components

3.8 LED Array Indication

LED	Behaviour
Power (green)	LED flashes every second as soon as the microcontroller of Sigma 05 is active. This indication is independent of the power source (USB or power terminals).
Error (red)	Constantly OFF: no errors detected LED flashes every second: fatal error (error code retrieval with PCS10) LED flashes shortly every two seconds: problems with Modbus probe configuration. Check the setup with PCS10 and/or the wiring.
Current outputs (orange)	Constantly ON: Two active current outputs. Constantly OFF: <ul style="list-style-type: none"> ▪ Sigma 05 is USB-powered, the analogue outputs are thus disabled or ▪ One output is set to voltage, the other to current.
Voltage outputs (blue)	Constantly ON: Two active voltage outputs. Constantly OFF: <ul style="list-style-type: none"> ▪ Sigma 05 is USB-powered, no analogue output possible or ▪ One output is set to voltage, the other to current. Orange and blue LEDs constantly ON simultaneously: Automatic probe discovery active or device is starting up and has not yet activated the configuration (approx. 1 s).

Tab. 6 Behaviour of on-board LED array

3.9 Display Functionality

3.9.1 Power Up, Scan

After power up in Automatic Probe Discovery mode (default setting), a progress bar made up of single points indicates Sigma 05 scanning the RS485 interface for sensing probes. A question mark appears approx. every 12 seconds as long as no probe is detected, see Fig. 3.



Fig. 3 Display during RS485 interface scan

As soon as one or more sensing probes are discovered, the display turns into normal operation.

3.9.2 Normal Operation

Depending on the number of measurands automatically or manually assigned to it, the display shows up to 3 lines with the measurand symbol, the measured value and the unit.



Fig. 4 Display layouts in normal operation

3.9.3 Configuration

If the Sigma 05 host device is connected with a PC via USB only (i. e. no voltage supply at the spring clamp terminals, see Fig. 5), the display shows the USB symbol.



Fig. 5 Sigma 05 with USB connection active only

Measured data flashing every second indicates that the corresponding measurand got beyond the thresholds defined via PCS10.

If the communication between Sigma 05 and any sensing probe is disturbed and consequently there is no measured data available, the corresponding display lines show "--,--". See Fig. 6.



Fig. 6 Sigma 05 with interrupted communication towards sensing probe(s)

Please refer to chapter 5 Manual Operation / Setup for a comprehensive overview of the configuration options.

4 Plug-and-Play Operation / Setup

4.1 General

This operation mode requires Sigma plug-and-play probes according to Tab. 6. The Automatic Probe Discovery of Sigma 05 sensor hub must be enabled (default setting).

The standard proceeding for starting plug-and-play operation:

- Mount the Sigma 05
- Connect the plug-and-play sensing probes
- Power up the Sigma 05

Upon power on, Sigma 05 starts automatically the „Automatic Probe Discovery“ process by scanning the RS485 interface.

On the electronics board, auto-discovery is indicated by the flashing green LED and the orange and the blue LED constantly on, see Tab. 5 (Behaviour of on-board LED array).

As soon as Sigma 05 discovers at least one probe, it autonomously performs the setup according to predefined rules. By this, the display layout and the analogue outputs are automatically set according to Tab. 6.

If needed, the predefined plug-and-play setup can be subsequently altered with the PCS10 Product Configuration Software, see chapter 5 Manual Operation / Setup.

#	Probe	Analogue Output 1				Analogue Output 2				Display Line 1		Display Line 2		Display Line 3	
		Measurand	Scale SI	Scale US	Measurand	Scale SI	Scale US	SI	US	SI	US	SI	US	SI	US
1	EE072	RH	0...100%	0...100%	T	-40...80 °C	-40...176 °F	RH [%]	RH [%]	T [°C]	T [°F]				
2	EE074	T	-40...80°C	-40...176 °F				T [°C]	T [°F]						
3	EE872-M13	CO ₂	Range of probe	Range of probe	RH	0...100 %	0...100 %	CO ₂ [ppm]	CO ₂ [ppm]	RH [%]	RH [%]				
4	EE872-M10	CO ₂	Range of probe	Range of probe				CO ₂ [ppm]	CO ₂ [ppm]						
5	EE671	v	Range of probe	Range of probe				v [m/s]	v [ft/min]						
6	EE680	vn	Range of probe	Range of probe	T	0...50 °C	32...122 °F	vn [m/s]	vn [ft/min]	T [°C]	T [°F]				
7	HA010406	RH	0...100%	0...100%	T	-40...180 °C	-40...356 °F	RH [%]	RH [%]	T [°C]	T [°F]				
8	EE072	RH	0...100%	0...100%				RH [%]	RH [%]						
	EE074				T	-40...80 °C	-40...176 °F			T [°C]	T [°F]				
9	EE872-M13	CO ₂	Range of probe	Range of probe				CO ₂ [ppm]	CO ₂ [ppm]						
	EE072				RH	0...100%	0...100%			RH [%]	RH [%]				
10	EE872-M10	CO ₂	Range of probe	Range of probe				CO ₂ [ppm]	CO ₂ [ppm]						
	EE072				RH	0...100%	0...100%			RH [%]	RH [%]				
11	EE671	v	Range of probe	Range of probe				v [m/s]	v [ft/min]						
	EE072				RH	0...100%	0...100%			RH [%]	RH [%]				
12	EE680	v	Range of probe	Range of probe				vn [m/s]	vn [ft/min]						
	EE072				RH	0...100%	0...100%			RH [%]	RH [%]				
13	EE872-M13	CO ₂	Range of probe	Range of probe				CO ₂ [ppm]	CO ₂ [ppm]						
	EE074				T	-40...80 °C	-40...176 °F			T [°C]	T [°F]				
14	EE872-M10	CO ₂	Range of probe	Range of probe				CO ₂ [ppm]	CO ₂ [ppm]						
	EE074				T	-40...80 °C	-40...176 °F			T [°C]	T [°F]				
15	EE671	v	Range of probe	Range of probe				v [m/s]	v [ft/min]						
	EE074				T	-40...80 °C	-40...176 °F			T [°C]	T [°F]				
16	EE680	vn	Range of probe	Range of probe				vn [m/s]	vn [ft/min]						
	EE074				T	-40...80 °C	-40...176 °F			T [°C]	T [°F]				
17	EE872-M13	CO ₂	Range of probe	Range of probe				CO ₂ [ppm]	CO ₂ [ppm]						
	EE671				v	Range of probe	Range of probe			v [m/s]	v [ft/min]				
18	EE872-M13	CO ₂	Range of probe	Range of probe				CO ₂ [ppm]	CO ₂ [ppm]						
	EE680				vn	Range of probe	Range of probe			vn [m/s]	vn [ft/min]				
19	EE872-M10	CO ₂	Range of probe	Range of probe				CO ₂ [ppm]	CO ₂ [ppm]						
	EE671				v	Range of probe	Range of probe			v [m/s]	v [ft/min]				
20	EE872-M10	CO ₂	Range of probe	Range of probe				CO ₂ [ppm]	CO ₂ [ppm]						
	EE680				vn	Range of probe	Range of probe			vn [m/s]	vn [ft/min]				

#	Probe	Analogue Output 1			Analogue Output 2			Display Line 1		Display Line 2		Display Line 3	
		Measurand	Scale SI	Scale US	Measurand	Scale SI	Scale US	SI	US	SI	US	SI	US
21	EE680	vn	Range of probe	Range of probe			vn [m/s]	vn [ft/min]			T [°C]	T [°F]	
	EE671				v	Range of probe	Range of probe			v [m/s]	v [ft/min]		
22	HTP501	RH	0 ... 100%	0 ... 100%	T	-40...120 °C	-40...248 °F	RH [%]	RH [%]	T [°C]	T [°F]		
	HTP501	RH	0 ... 100%	0 ... 100%				RH [%]	RH [%]	T [°C]	T [°F]		
23	EE074				T	-40...120 °C	-40...248 °F					T [°C]	T [°F]
	MOP301	aw	0 ... 1	0 ... 1	T	-40...120 °C	-40...248 °F	aw [-]	aw [-]	T [°C]	T [°F]		
25	MOP301	aw	0 ... 1	0 ... 1				aw [-]	aw [-]	T [°C]	T [°F]		
	EE074				T	-40...120 °C	-40...248 °F					T [°C]	T [°F]

5 Manual Operation / Setup

The Sigma 05 is ready to use and does not require any configuration by the user. The Sigma 05 factory setup corresponds to the type number ordered. Please refer to the data sheet at www.epluse.com/sigma05. The user can change factory setup with the help of the PCS10 Product Configuration Software and the USB cable for connecting Sigma 05 to PC (HA010327).

1. For changing the factory setup of the sensor platform with PCS10, proceed as follows:
2. Download the PCS10 Product Configuration Software from www.epluse.com/pcs10 and install it on the PC. PCS10 requires Windows 8.1 or higher.
3. Connect the Sigma 05 to the PC using the USB connection cable.
4. Start the PCS10 software.
5. On the PCS10 opening page scan the ports and identify the connected device.
6. Click on the desired Sigma 05 hub device and disable the “Automatic probe discovery” in the “Probe settings” view.

i PLEASE NOTE

As long as the “Automatic probe discovery” is enabled, the PCS10 only shows information on the Sigma 05 and on the connected probes, as well as the measured data in the “Live View” view. All configuration features are disabled.

7. Start configuration. Please observe the PCS10 Help dropdowns for further information.

i PLEASE NOTE

The USB interface provides power supply to the Sigma 05 electronics only. In this case, the probes connected to Sigma 05 are not powered and consequently, the functions of the PCS10 are limited.

The limited setup functionality (for USB supply only) includes:

- Set the individual device name
- Export and import Sigma 05 configuration

For full setup functionality the Sigma 05 must be powered at the spring clamp terminals. The full setup functionality additionally includes:

- Read the measured data
- Add and assign measurands from the probes
- Add new probes
- Change the probe communication parameters
- Change the display layout
- Change the output signals
- Scale the outputs
- Set warning thresholds for the measurands on the display
- Set the error indication on the analogue outputs, see chapter 6.5.
- Perform offset and 2-point adjustment of the probes connected to Sigma 05

6 Maintenance and Service

6.1 Display Change and Retrofitting

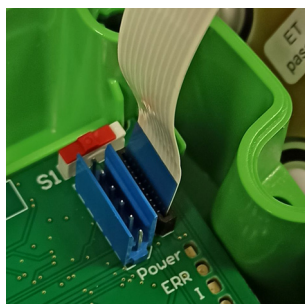

Fig. 7 FFC cable connection on the Sigma 05 electronics board

When connecting the display's FFC cable to the Sigma 05 electronics board, please observe the correct orientation. The blue cable stiffener needs to be on the left side as shown in Fig. 7.

6.2 Firmware Update

Connect the Sigma 05 to a PC. Start the PCS10 Product Configuration Software while the PC is connected to the internet, and scan the COM port connected to Sigma 05 as described in chapter 5 Manual Operation / Setup, point 4. If there is a firmware update available, it will be indicated in the "Information" view of the PCS10. Select the desired update by clicking on it, then proceed by clicking on the "Update firmware" button. Refer also to the help pop-up in the "Information" view.

6.3 Reference Probe

The Reference Probe Modbus RTU (HA010406) facilitates a functional and accuracy check of the Sigma 05 sensor hub. Please refer to the Reference Probe's Quick Guide at www.epluse.com/sigma05.

NOTICE

Power off Sigma 05 before connecting or disconnecting sensing or reference probes. Failing to do so may cause damages to Sigma 05 and to the probes.

6.4 Repairs

Repairs may be carried out by the manufacturer only. The attempt of unauthorized repair excludes any warranty claims.

6.5 Error Indication on the Analogue Output (NAMUR)

The Sigma 05 sensor hub features an error indication on the analogue outputs according to the NAMUR NE 043 recommendations (Standardization of the Signal Level for the Failure Information of Digital Transmitters, Edition 2003-02-03, see www.namur.net/en/recommendations-and-worksheets/current-nena.html).

The feature is enabled by factory default and can be disabled and configured with the PCS10 Product Configuration Software.

Output Signal	NAMUR Signal Level
0 - 5 V	5.5 V
0 - 10 V	11 V
0 - 20 mA	21 mA
0 - 20 mA	21 mA

6.6 Spare Parts

Description	Code
Display for Sigma 05 for polycarbonate enclosure	D09P

7 Accessories

For further information please refer to the [Accessories](#) datasheet.

Accessories	Code
Modbus configuration adapter	HA011018
PCS10 Product Configuration Software (Free download: www.epluse.com/pcs10)	PCS10
Connection cable M12-M12 unshielded L = 2 m (6.6 ft) L = 5 m (16.4 ft) L = 10 m (32.8 ft)	HA010813 HA010814 HA010815
Reference Probe Modbus RTU	HA010406
Power supply adapter 100 - 240 V AC to 24 V DC not DNV approved	V03
USB cable for PC connection (USB-A to USB-C)	HA010327
M12 Y adaptor	HA030204
M12x1 cable connector for self-assembly, 5 pole socket	HA010708
M12x1 cable connector for self-assembly, 5 pole plug	HA010706
Protection cap for M12 female connector	HA010781
Protection cap for M12 male connector	HA010782

8 Technical Data

Probe connection

Max. number of sensing probes ¹⁾	3
Max. number of measurands	5 (2 on the analogue outputs, 3 on the display)
Electrical connection	M12x1 socket 5 poles

1) Compatible E+E probes see section "Plug-and-Play Probe" above.

Digital

Probe interface	RS485
Protocol Factory settings Supported Baud rates ¹⁾ Measured data types	Modbus RTU 9 600 Baud, 8 databits, parity even, 1 stop bit 9 600, 19 200, 38 400, 57 600, 76 800 und 115 200 FLOAT32 and INT16





1) For details on the communication setting refer to the User Manual and the Modbus Application Note at www.epluse.com/sigma05.

Outputs

Analogue

Two freely selectable and scalable outputs	0 - 1 / 0 - 2,5 V / 0 - 5 / 0 - 10 V -1 mA < I_L < 1 mA 4 - 20 mA 3-wire 0 - 20 mA 3-wire	$R_L < 500 \Omega$ $R_L < 500 \Omega$	I_L = load current R_L = load resistance
Accuracy of analogue outputs at 20 °C (68 °F)	0.02 % FS for 0 - 10 V and 0 - 20 mA		FS = full scale

General

Power supply class III  USA & Canada: Class 2 supply necessary	15 - 30 V DC		
Supply current to the probes, max.	0.5 A		
Electrical connection	Screw terminals max 2.5 mm ²		
Cable glands	Cable gland M16x1.5, for cable \varnothing 4...8 mm (0.16...0.31")		
Configuration interface	USB-C on the electronics board		
Working and storage conditions Without display With Display	0...95 %RH, non-condensing 700...1 200 mbar -40...+60 °C (-40...+140 °F) -20...+50 °C (-4...+122 °F)		
Enclosure		Plastic	Metal
	Material	Polycarbonate	Aluminium Al 383
	Protection rating ¹⁾	IP65 / NEMA 4X	IP65 / NEMA 4
	Conformity	UL94 V-0, with Display UL94 HB approved	
Electromagnetic compatibility	EN 61326-1:2013 FCC Part15 Class A	EN 61326-2-3:2013 ICES-003 Class A	Industrial Environment DNV-CG-0339
Conformity	   ²⁾		
Type approval	DNV Certificate No. TAA00003FA		
Configuration software	PCS10 Product Configuration Software Free download from www.epluse.com/pcs10 .		

1) With appropriate cable / probe connector (M12x1 female), see section "Accessories" below.

2) DNV scope of approval: please refer ordering guide.

9 Conformity

9.1 Declarations of Conformity

E+E Elektronik Ges.m.b.H. hereby declares that the product complies with the respective regulations listed below:



European directives and standards.



UK statutory instruments and designated standards.



DNV (Det Norske Veritas) maritime type approval.

Please refer to the product page at www.epluse.com/sigma05 for the Declarations of Conformity.

9.2 FCC Part 15 Compliance Statement

This equipment has been tested and found to comply with the limits for a Class A digital device, pursuant to part 15 of the FCC Rules. These limits are designed to provide reasonable protection against harmful interference when the equipment is operated in a commercial environment. This equipment generates, uses, and can radiate radio frequency energy and, if not installed and used in accordance with the instruction manual, may cause harmful interference to radio communications. Operation of this equipment in a residential area is likely to cause harmful interference in which case the user will be required to correct the interference at his own expense.

9.3 ICES-003 Compliance Statement

This Class A digital apparatus complies with Canadian ICES-003.

Cet appareil numérique de la classe A est conforme à la norme NMB-003 du Canada.

9.4 DNV Type Approval

Approval standard DNV-CG-0339:2021

Location Classes	
Temperature	D
Humidity	B
Vibration	B
EMC	B
Enclosure	B / IP65

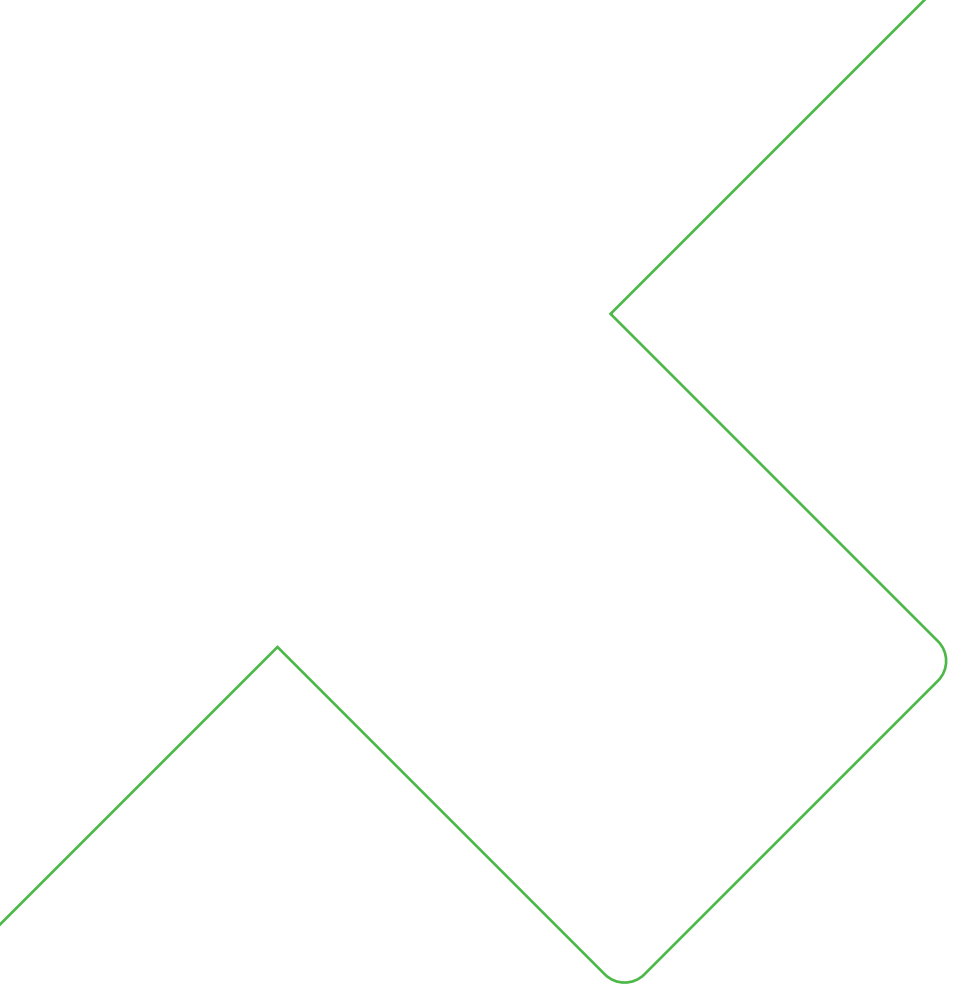

Company Headquarters &
Production Site

E+E Elektronik Ges.m.b.H.
Langwiesen 7
4209 Engerwitzdorf | Austria
T +43 7235 605-0
F +43 7235 605-8
info@epluse.com
www.epluse.com

Subsidiaries

E+E Sensor Technology (Shanghai) Co., Ltd.
T +86 21 6117 6129
info@epluse.cn

E+E Elektronik France SARL
T +33 4 74 72 35 82
info.fr@epluse.com

E+E Elektronik Deutschland GmbH
T +49 6171 69411-0
info.de@epluse.com

E+E Elektronik India Private Limited
T +91 990 440 5400
info.in@epluse.com

E+E Elektronik Italia S.r.l.
T +39 02 2707 86 36
info.it@epluse.com

E+E Elektronik Korea Ltd.
T +82 31 732 6050
info.kr@epluse.com

E+E Elektronik Corporation
T +1 847 490 0520
info.us@epluse.com



—
your partner
in sensor
technology.